



PRODUCT FEATURES

- Permits electronics to be mounted on fence posts or gate posts
- Brackets are reversible
- Bracket kits include brackets, mounting hardware and post shims
- Post brackets are pre-drilled
- Zinc-plated steel provides durability and long life
- Bolt on or weld for installation
- Compatible with maximum 3" round post with minimum pole separation of 1"
- Use with Post Shim Brackets for smaller post sizes
- MagnaCare® lifetime replacement, no fault warranty

Notes:

- M62FG can be direct mounted on square posts
- To use FMK-SL with M62FG-SASM, post separation should be 1" to 2-1/4"
- To use FMK-SW with M62FG or the GL1, post separation should be 1" to 2-3/4"
- To use FMK-SL with GL1 or M62FG, post separation should be 1" to 3-3/4"

SPECIFICATIONS

Shipping weight:
7 lbs (3.18kg)

Sliding Gate

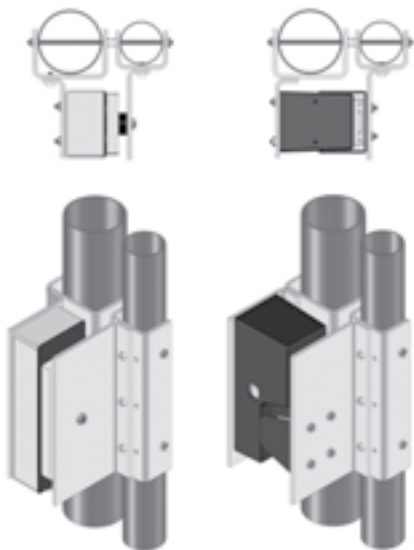

FMK-SL shown with M62FG

FMK-SL shown with GL1

FMK

Flex-Mount Gate Lock Bracket Kits

Bracket Kits Extend Access Control to Gates and Fences

The FMK Flex-Mount Bracket System is an intuitive set of mounting brackets designed exclusively for use with the M62FG Magnalock® and the GL1 Gate Lock. Pre-formed post channels and plates of varying lengths make it easy for you to assemble a professional looking, high-security gate lock mounting platform in minutes, without special tools.

MODELS

PART #	Description
FMB9-4	Post Shim Kit for Flex Mount Brackets - (Set of 4)
FMK-SL	Flex Mount Kit for Sliding Gate
FMK-SW	Flex Mount Kit for Swing Gate



FMK-SW shown with M62FG

FMK-SW shown with GL1

