

SECURITRON PB2 SERIES EXIT BUTTON INSTALLATION AND OPERATING INSTRUCTIONS

1. DESCRIPTION

The model PB2 is a spring loaded momentary 2" square, exit button, mounted on a stainless steel single gang outlet box cover. The SPDT contacts switch when the button is depressed and return when it is released. The contacts are UL listed with 5 AMP capacity. The indicator LED is mounted above the button and the switch LED illuminates the button itself.

The indicator LED and switch LED can be individually operated according to the needs of the installation. The PB2 can be used for momentary release of fail safe or fail secure electric locks. If interfaced with a release hold timer, such as Securitron's TimeMate, it can provide for **timed release** of electric locks. It may also be used to input a REX (request to exit) signal to a card reader system. We recommend that the local building or fire safety authority be consulted prior to using exit buttons for door egress. They may require a "no special knowledge" exit device such as Securitron's Touch Sense Bar.

2. INSTALLATION

The PB2 comes with a plastic mounting device and color coded hookup wires installed. If a enclosed box is used, be sure it is at least 2 1/2" deep to accommodate the switch. The drawings below show identification of the unit's connection points.

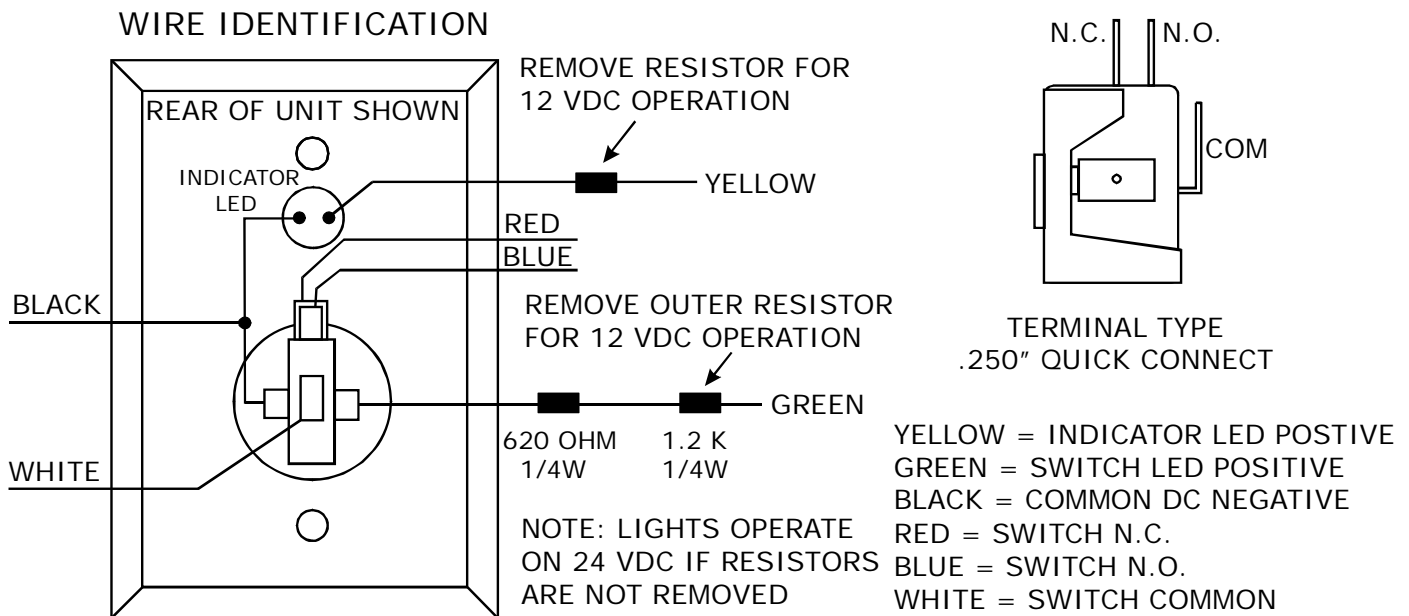

Figure 1

3. LED OPERATION

Resistors are installed so that the LEDs may be operated on either 12 or 24 VDC. The yellow wire drives the indicator LED and the green wire drives the switch LED. Both wires have resistors soldered on them. If the power supply is 24 VDC, connect directly to the wires. If the power supply is 12 VDC, remove the resistor for proper operation at the lower voltage. See Figure 1. The indicator LED draws 20 mA and the switch LED draws 9 mA @ 12VDC or 20 mA @ 24VDC.

4. WIRING

The PB2 can be used in many different ways but the drawings below show two common applications. The first shows momentary release of a fail safe or fail secure electric lock. The PB2 indicators are connected so that the switch LED is normally on. When the button is pressed, releasing the lock, the switch LED turns off and the indicator LED comes on. The second drawing shows timed release of a fail safe electric lock using the PB2 and Securitron's TimeMate.

Momentarily pressing the button will release the lock for the amount of time set on the TimeMate. The indicator will change colors during the lock release period. The wiring is also done in double break fashion so that even if the timer fails, the button will still be able to momentarily release the lock. This is for added safety.

MOMENTARY RELEASE OF FAIL SAFE OR FAIL SECURE ELECTRIC LOCK

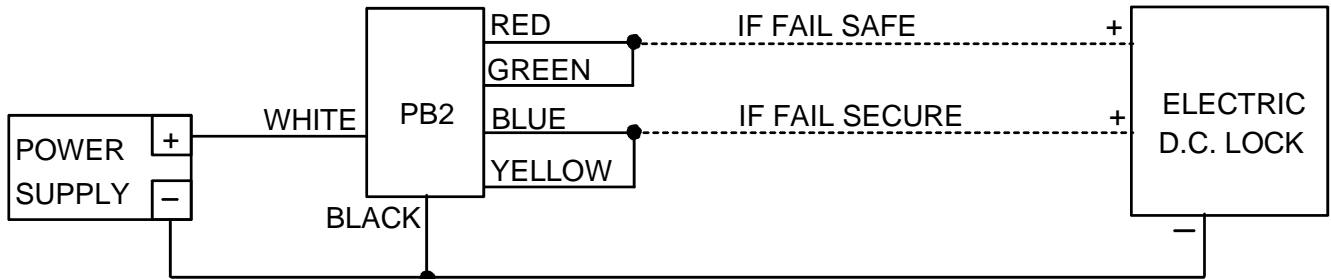

TIMED DOUBLE BREAK RELEASE OF FAIL SAFE LOCK

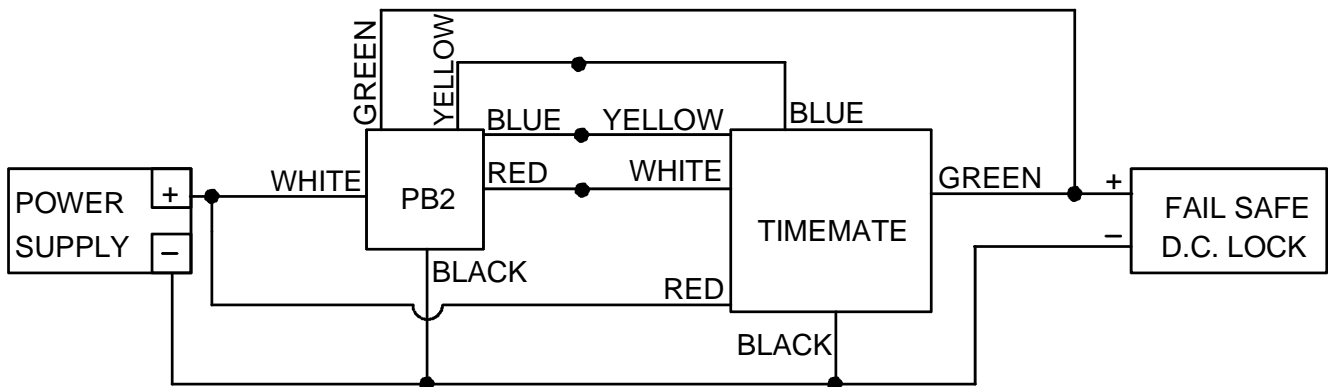

5. ALTERNATE LENS CHANGING

The pushbutton is factory shipped with the green lens set installed and two lens/insert options. Changing to the other lens sets is simple.

- 1) Grasp keyplate and turn over. From the back rotate the white contact block of the switch counter-clockwise to the 11 o'clock position and pull straight back to remove the contact block.
- 2) With a slender smooth ended object such as a marker pen, slide it inside the switch body until it stops against the back of the lens. Place the object that is inside the switch body on a smooth surface with the keyplate on top, and tap the keyplate up and down on the object to pop the lens off. Remove the lens and insert.
- 3) Turn the keyplate over and place the new insert onto front of switch, confirm that the text on the insert is correct reading to the keyplate and place the matching colour lens on top of the insert and compress around all edges of the lens until it snaps in place. Depress lens several more times to ensure smooth operation and that the lens is not binding.
- 4) With the terminals upward insert the contact block back into the back of the switch at the 11 o'clock position and rotate clockwise until it stops straight up and down.

6. LED REPLACEMENT

The switch LED is replaced by grasping the back of the white contact block and twisting it counter-clockwise to the 11 o'clock position, pull the contact block straight out of the rear of the switch. This reveals the LED which then can be pulled out from the block. Note: LED is polarity sensitive. Insert new LED into contacts, the ⊕ marking on the LED should be on the same side as the green wire with printing facing the same directions as the switch block terminals. Operating Life of the switch LED is 100,000 hours. Reverse step to lock contact block back into switch body.