

XMS2 Exit Motion Sensor

SECURITRON
ASSA ABLOY

Installation Instructions

Experience a safer
and more open world

Product Components

- A XMS2 (assembled)
- B Cover
- C Back Plate
- D Screw Pack
- E Install Instructions (not shown)

Recommended Tools

- Power Drill
- Hammer / Mallet
- Wire Strippers / Cutter
- Flat Head Precision Screw Driver
- Phillips Head Screw Driver
- Crimp Wire Connectors
- Crimp Tool
- Fish Tape or Lead Wire
- Multimeter
- Thread Lock

Specifications

	XMS2
Length	7.125" (180.975mm)
Height	1.75" (44.45mm)
Depth	1.87" (47.625mm)
Input Voltage	12-24 VDC
Current at 12-24 VDC	20-70 mA depending on switching status
Rex Relay	Max 1A @ 30VDC (Resistance Load only)
Lock Control Relay	Max 1A @ 30VDC @ 77°F (25°C)
Operating Temperature	32° to 120°F (0° to 49°C)
Humidity	0-85% non condensing
Detection Range Whole Body	Nominal
Detection Range One Hand	Nominal

Diagram 1 Product Components

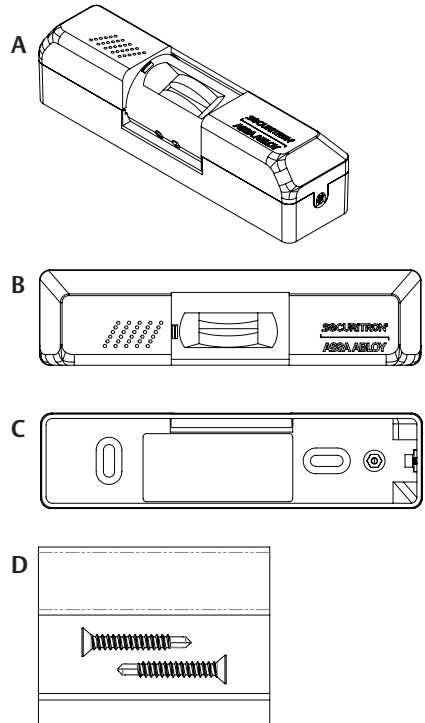

IMPORTANT This product must be installed according to all applicable building and life safety codes. Unit is intended for indoor use only. This Product shall not impair the intended operation of panic hardware used in conjunction with it.



IMPORTANT The power source for this unit shall be derived from a power supply limited Class 2, UL294, UL603 or UL2610 Listed Power Supply. Wiring Methods used shall be in accordance with the National Electrical Code, ANSI/NFPA 70.



IMPORTANT UL294 Performance Ratings: (required per Chapter 10 of 2015 IBC)

Destructive:	Level I	Line Security:	Level I
Endurance:	Level IV	Standby Power:	Level I

Description

NOTE: Since egress from a magnetically locked door can be a safety issue, make sure you are complying with local building codes. Contact your building and/or fire prevention department.

The XMS2 is a passive infrared motion detector specifically designed to release a magnetic lock from the inside of an opening for free egress. Unlike burglar alarm type detectors, the XMS2 has special features appropriate to this use. The lock control function is fail safe so that the magnetic lock will safely release if power is cut to the detector. A relay is also present to send a REX (request to exit) signal to an access control system (if one is present) and therefore shunt an alarm report. A time extension feature avoids the problem of the unit resetting if a person momentarily stops moving just before an exit. Tight control of the exit detection pattern allows maximum security from the outside and avoidance of inadvertent activation from the inside.

Diagram 2 Cover Removal

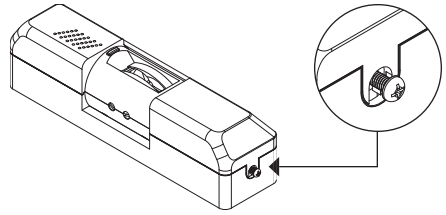

Diagram 3 Interior of Unit

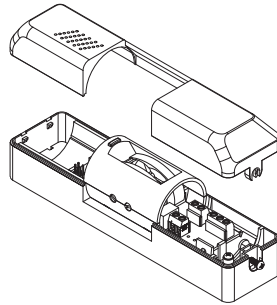

Diagram 4 Barrel Locking Screw

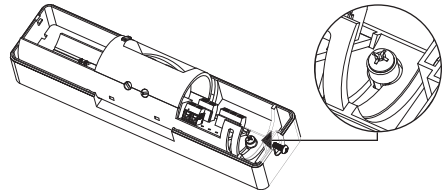

Diagram 5 Barrel Removal

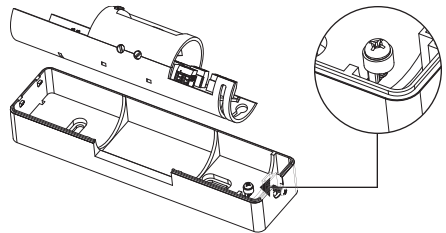
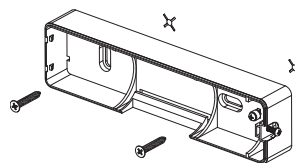

Diagram 6 Back Bracket



Physical Installation

NOTE: XMS2 is intended for indoor use only.

Fixing the unit to the wall:

- 1 LOCATE** the screw on the end of the unit to loosen it (Diagram 2). This permits you to remove the cover.
NOTE: The appearance of the interior is shown (Diagram 3).
NOTE: The interior electronic board is mounted on a rotating barrel which is locked by the "Barrel Locking Screw".
- 2 LOOSEN** the Barrel Locking Screw and rotate the barrel fully upward so that it can be removed (Diagram 4 / Diagram 5).
- 3** Once the Barrel is removed you will have the back bracket to use as a template. You will see two slotted holes for physical mounting of the rear housing and a choice of two wire entry points.
NOTE: Most Installers prefer to pull the cable thorough the wall first and them mount the bracket to the wall.
- 4 MOUNT** the back bracket to the wall using the hardware provided (Diagram 6).
- 5 REPLACE** the barrel assembly.
- 6 ATTACH** the wires to the screw terminals.
NOTE: Coverage with XMS2 is dependent on placement of the unit (Diagram 7).

Diagram 7 Coverage Diagram

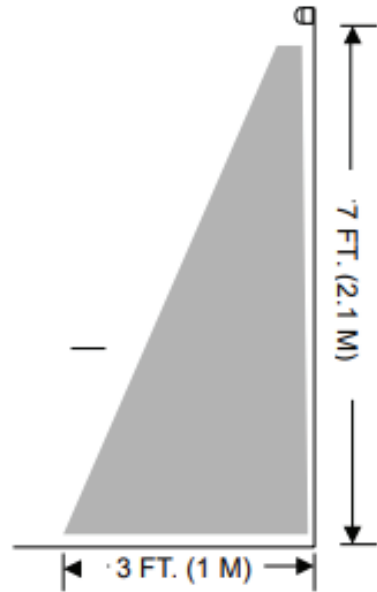

Placement of the Unit

NOTE: XMS2 is intended for indoor use only (Diagram 8).

Position the XMS2 with respect to the inside of the door so that its detection pattern will “see” a person approaching the door while maintaining good security from the outside. There are different options as to where the unit is placed depending on variables in the application (Diagram 8).

The simplest method of placing the unit is for traffic control applications. A traffic control application is one where you do not expect any attempt at breaking in from outside. The unit is simply centrally positioned above the door with the pattern covering the door.

For security applications, you will set your position to defend against someone activating the detector from the outside. To deal with this threat, the unit is positioned above and outside of the door hinges with the pattern adjusted so that it sweeps across the door but does not detect the bottom of the door. If the door includes an exit bar, the pattern must be broad as a person’s approach to the door is variable. If it includes a door knob or lever handle, the pattern can be adjusted more narrowly. A final option for security applications is to position the unit at the side of the door so that it sees across the door. This can be used for doors at the end of corridors. You would not want to employ this approach for non corridor doors as the door would be released by someone walking near it (maximum detection range is approximately 20 ft.) Side of door mounting has the disadvantage of greater exposure to vandalism but defends against objects being inserted under the door and provides excellence coverage along the full width of the door . Note that for the end-of-corridor application, the unit can be positioned on the same wall plane as the door or on a wall which is next to the door and perpendicular to it. The pattern can be adjusted a full 90 degrees with respect to the sensor’s mounting plane.

Diagram 8 Product Placement Options

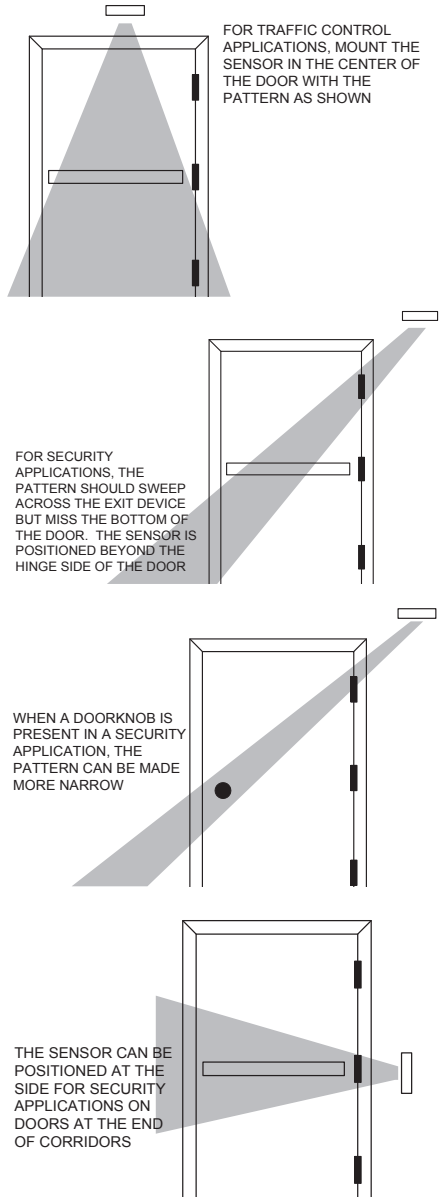

Wiring

NOTE: Input voltage must match the required voltage of the maglock being controlled.

To power the unit, filtered and regulated DC Voltage between 12 and 24VDC should be applied to the power input terminals (Diagram 9). This connection should be permanently made to the power supply and not switched through another device. The XMS2 should receive constant power. Make sure you observe correct polarity with this connection. If you reverse the input power polarity, the unit will not be damaged but will appear to be dead.

Wiring with a Magnetic Lock Only

This is the simplest application which releases the magnetic lock from the inside for free egress but is not concerned with shunting any alarm point at the door.

NOTE: Positive power to the lock connects through the terminal block "IN+" and "DEVICE".

The IN+ and DEVICE terminals constitute an internal field effect transistor which does the actual switching (Diagram 10). If the power to the XMS2 was somehow interrupted, the field effect transistor would automatically open, releasing power to the lock. This function makes the XMS2 "fail safe".

NOTE: Never use the REX relay contact to switch the magnetic lock. The REX contact only has enough capacity for signaling; they cannot reliably switch magnetic lock current.

Diagram 9 XMS2 Overview

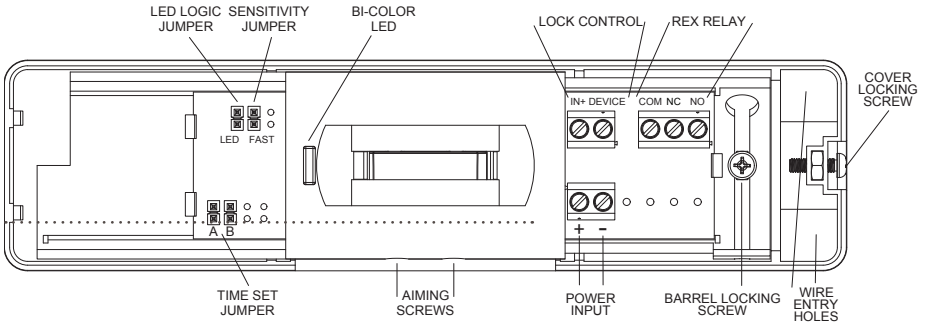
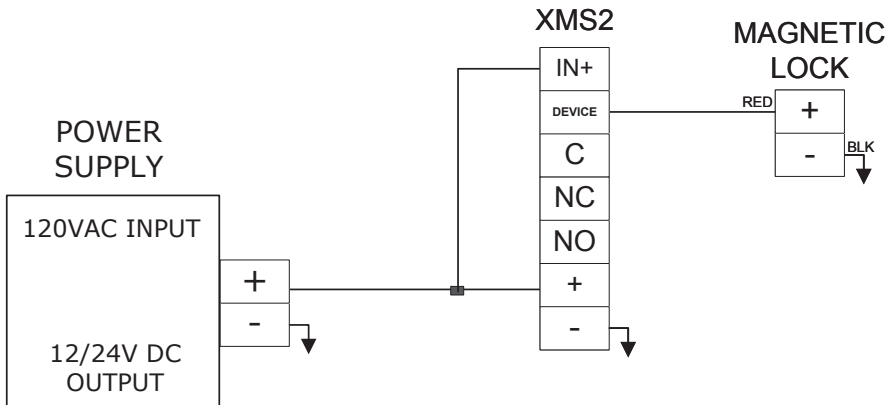

Diagram 10 Wiring Magnetic Lock Only



Wiring with a Controlled Entry Unit

Integrating a controlled entry unit such as a digital keypad, would use a set of NC contacts from the entry unit to break the wire connection between DEVICE and the magnetic lock + to allow the entry unit to release the lock (Diagram 11).

Shunting and Alarm Point

This technique for installations where the door is connected to an alarm system and that if the door opens without the XMS2 having been activated, an alarm signal should result. When the

XMS2 is employed to open the door, the alarm signal should be shunted.

The alarm system will be connected to a door position switch or other detector at the door via two wires. You will need to determine if this loop is closed when the door is closed and opens when the door opens or is the opposite, open when the door is closed and closed when the door opens. Correct wiring to shunt the alarm is shown for both instances (Diagram 12 / Diagram 13). You utilize the REX relay contacts for this shunting while the lock control relay contacts continue to release the magnetic lock.

Diagram 11 Wiring with Entry Device

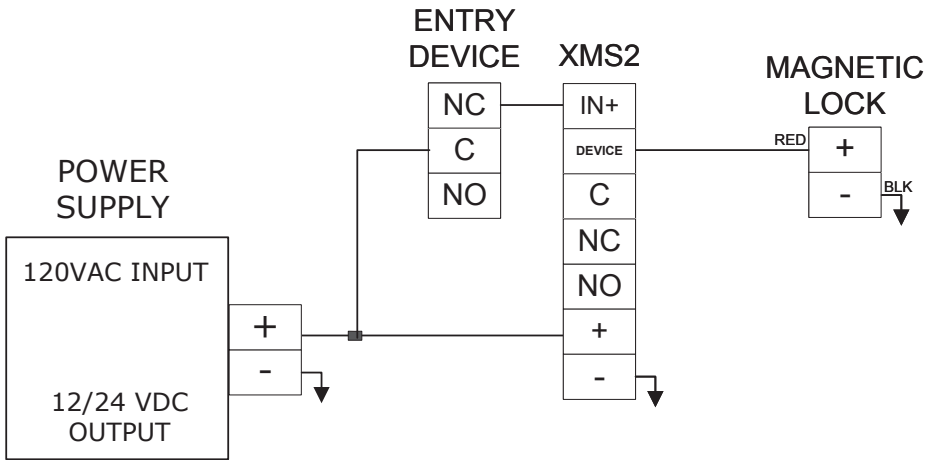

Diagram 12 Alarm Signal Closed with Door Closed

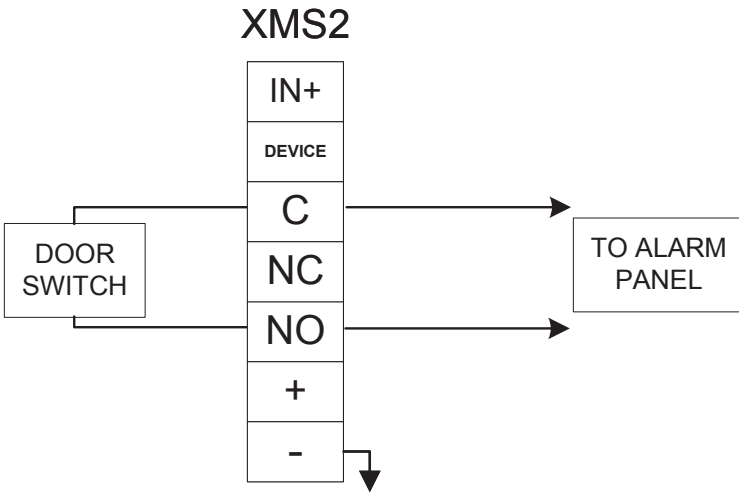
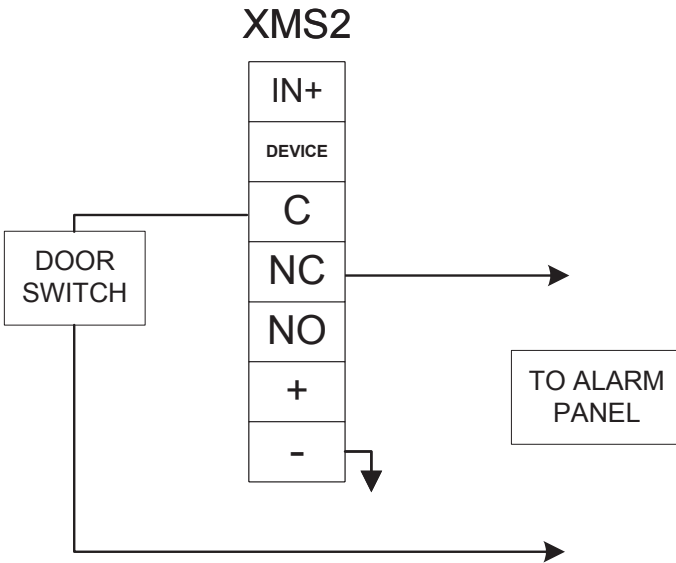

Diagram 13 Alarm Signal Open with Door Closed



Integration with Access Control System

An access control system permits entry and will also often act as an alarm system if a door is forced. To integrate with the XMS2 and a magnetic lock, the access control system should have a two terminal REX (request to exit) input. When this input is closed, the access control system will operate its lock control relay to release the lock and will not create an alarm signal as it will consider the exit event an authorized one. Wiring is shown (Diagram 14).

NOTE: With this wiring method, the lock control terminals of the XMS2 directly break power to the magnetic lock as do the access control system contacts. This is called double break wiring.

This wiring enhances safety and reliability as if the access control system experiences a fault, the XMS2 still allows safe egress. If the access control system is not monitoring the door, connection to the REX input is not required. In that case make all other connections as shown (Diagram 14) except the REX input.

In some jurisdictions, the combination of a magnetic lock, access control system and Exit detector such as the XMS2 can be considered an access controlled egress door. The applicable section of the Life Safety Code calls for a redundant means of exit in the event of a problem with the detector. This is typically a push button located 40–48 inches above the floor and within five feet of the door. Pushing the button will directly release power to the magnetic lock and the lock shall remain released for 30 seconds. This can be accomplished with any of the Securitron push buttons and the TM-9 timer and EEB push button series with integrated timers. The EEB series is easy to use with the XMS2 to satisfy code requirements with its factory set 30-second integrated timer, for access controlled egress doors (Diagram 15).

Diagram 14 Wiring with an Access Control System

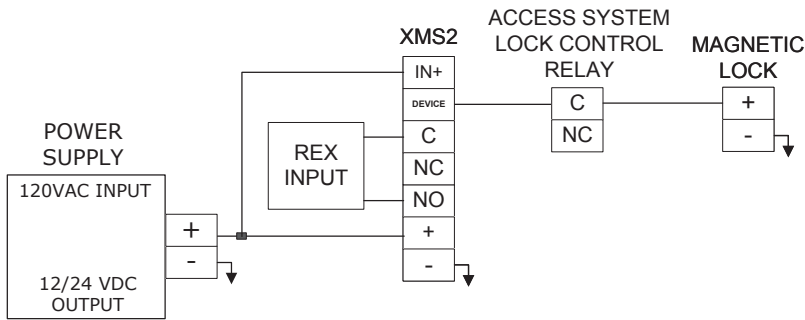
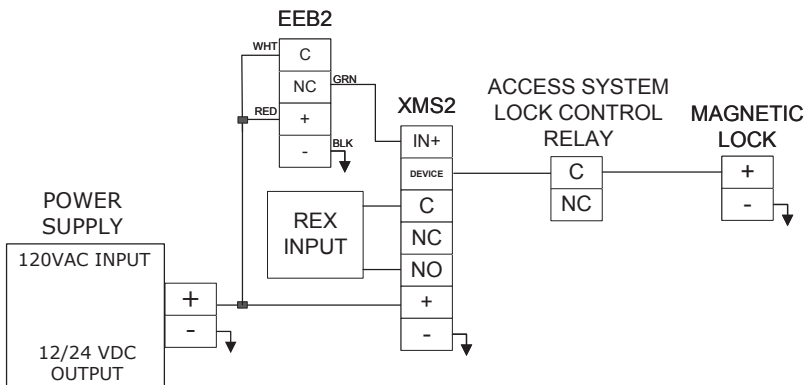

Diagram 15 Wiring with a timed EEB Button and Access Control System



Basic Operation

When the XMS2 is first powered its LED will flash quickly twice every second for about 30 seconds. This is a self test and permits the XMS2 to adjust itself to the thermal environment that it sees. After this start up period the LED will stay green. If the self test fails during the start up period, the LED will begin to flash 4 times per second. This failure indication will continue indefinitely. If this failure indication occurs un-power the unit for 30 seconds and re-power the unit. During the self test period the unit's control outputs are in their normal conditions (lock control conducting, REX relay de-energized).

NOTE: If the failure indication occurs again after cycling power please contact the factory for a RMA replacement of the unit.

In the event of a very brief power outage, the unit will not self test for 30 seconds but will undergo a self test of 10 seconds before resuming normal operation.

NOTE: The self test on power up feature of the unit is why the XMS2 must receive constant power.

Once the unit passes its self test, it will be able to detect moving objects that are a different temperature than the ambient. With jumpers in the factory set configuration, it will signal this detection by switching its LED from green to red.

NOTE: The LED mirrors the state of the REX relay rather than the lock control transistor.

You need to understand how the XMS2's control outputs operate in a detection event. In the rest condition (green LED on; no detection), the lock control transistor is conducting and the REX relay is de-energized. When an object is detected, the REX relay energizes immediately. This is to shunt alarm contacts or send a REX signal to an access control system. Fifty milliseconds later, the lock control transistor switches off which releases the magnetic lock. The brief delay is to make sure that the access control system has processed the REX signal so that it won't alarm if it is also reading lock status

detection such as the Securitron Bondstat feature. A lock status signal will change state as soon as the lock is de-powered. The REX relay will remain energized as long as the lock control transistor is continuing to release the lock. When the lock re-secures, the REX relay will remain energized for an additional second to allow the magnetic lock to fully engage and report secure in the event that it is reporting lock status to an access control system.

In the factory set condition, the lock control transistor will remain off for 4 seconds after detection has ceased (keeping the lock released). If, during the 4 seconds, the object moves again, the detection condition will be maintained for another 4 seconds after this "new" detection ceases.

For the magnetic lock to re-secure, 4 seconds must pass with no detection, this trailing edge timing feature is for egress safety and reliability. Otherwise, it would be possible for a person to approach the door, activating the XMS2, but then stop moving for a brief moment at the door. The detector would reset and if the person quickly lunged into the door they the movement could be quicker than the detection response to the movement and the door would not open as quick as the person moving into it. The 4 second trailing edge timing feature virtually eliminates this potential issue. Another operational safety feature is the fact that if proper power is cut to the XMS2, the lock safely releases so that a person is not trapped. This trailing edge timer of 4 seconds can be reconfigured using the jumper setting on the board of the XMS2.

Jumper Settings

The XMS2 has 3 jumper settings that control LED logic, timing logic, and sensitivity.

The LED logic jumper controls the logic of the bi-color LED. When left in the factory set position, (jumper installed) the LED will illuminate red during a detection event and return to green in the resting condition. Removing the jumper will reverse the colors noted in the above logic.

The Sensitivity jumper makes the unit sensitive to movement in the factory set condition (jumper installed). Removing the jumper will decrease the sensitivity.

The Time-Set jumper can be installed in any of three positions to alter the factory set trailing edge delay of 4 seconds. The diagram to the right shows the three choices.

When setting the time set jumper 4 seconds is right for most applications, a 1/2 second would be used for pattern set up and certain applications where an external timer should replace the XMS2 timer. For example, when the XMS2 is integrated with an access control system, the XMS2's REX relay will trigger the access system's lock control relay and the magnetic lock will release for the same amount of time that is programmed for entry. If the time-set jumper is installed for the 1/2 second setting and assuming a person is initially sensed by the XMS2, Then does not immediately exit but moves around the front of the door, they will continue to retrip the XMS2. Persistent retripping of the XMS2 however, will cause the Lock Control and REX Relay to remain latched until no movement is sensed for a time greater than the set 1/2 second. It is important to note that this device has a "trailing edge" delay—i.e. the device Lock Control and REX Relay will remain latched until a time greater than the set time has expired since the last detected movement. The XMS2, when integrated with an access controls system, is best set at a 1/2 second timing. If the XMS2 is set at 4 seconds the following may occur on initial release. The access system would start timing for 10 seconds (as an example),

but the person does not immediately exit the door and instead moves around in front of the door so the XMS2 signal does not change and stays closed due to the 4 second timing function, if the door is then used, a forced door alarm signal will result.

Another application where you should employ the 1/2 second setting is when the XMS2 is employed to initiate delayed exit when you are using a Securitron model XDT timer.

The 8 second setting is rarely used unless there is strong concern for maximum time being allocated for egress even when movement is not maintained. The problem with an 8 second trailing edge delay is that entry security begins to be compromised.

Diagram 16 Time Set Jumper

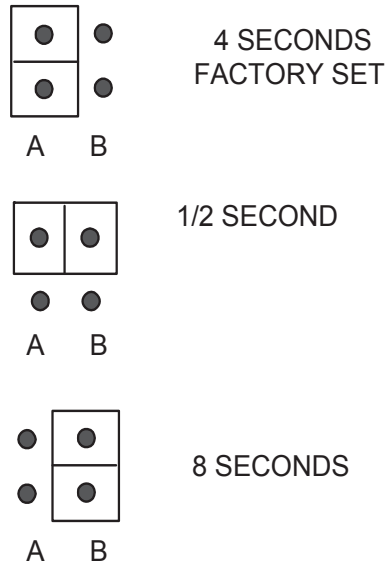
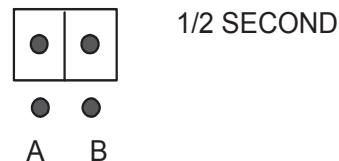

Diagram 17 1/2 Second Time Set Jumper



Detection Pattern Set-Up

At this point in the installation, the unit should be physically mounted and wired. You should have also considered changing the jumper settings. Your final step is to adjust the detection pattern for the optimum combination of egress safety and entry security. Before doing this, set the time set jumper to the 1/2 second position (shown in the drawing to the right). As you are adjusting the pattern, you will make many quick tests of the unit and this will be most efficient if you don't have to wait for a 4 or 8 second trailing edge timer to expire.

The XMS2 provides two means of adjustment. First, the entire barrel assembly rotates 90 degrees so that the unit can look "out" or "down". Second, aiming screws are provided to laterally control the pattern. To access the aiming screws, the barrel assembly must be rotated so that the unit looks "out" so while you are making these adjustments, you will need the barrel locking screw to be loose (see Diagram 4).

In most applications, the unit is set to look "down". The exception would be if the XMS2 was mounted on a wall perpendicular to the door rather than parallel to it. As the detection pattern proceeds outward from the XMS2 it spreads in the same direction as the barrel rotates rather than lateral spreading which is constrained by the aiming screws. The drawing on the right provides an example of this spreading. Assuming the XMS2 is mounted seven feet above the floor, the pattern will spread out roughly three feet by the time it reaches the floor. Maximum detection distance is approximately 20 feet.

The aiming screws control internal louvers that point the same way as the slots in the screws. When adjusting these screws, do not turn them past the point where you feel resistance as they can take the louvers "off track". Diagram 18 shows the typical relationship between the aiming screw orientation and the resultant detection pattern.

To set your pattern laterally, experiment with the aiming screws as is shown in Diagram 18. Each time you alter the aiming screw setting, you will have to rotate the barrel assembly up and down. Test the pattern by moving in it and observing the limits of detection by watching the LED. When you are satisfied with the aiming screw settings, you must also finalize the

degree of barrel assembly rotation. You don't want the unit "seeing" the surface of the door itself as this can lead to false detection, so in the common case where the unit mounts in the same plane as the door, you do not want the barrel assembly adjusted at full 90 degrees. It should face slightly away from the door.

When you are entirely satisfied, be sure to tighten the barrel locking screw and restore the time set jumper to the 4 second position (if necessary). Then replace the cover.

Diagram 18 XMS2 Aiming Screws

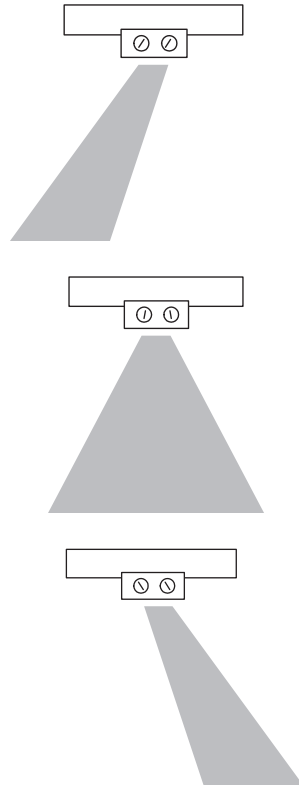
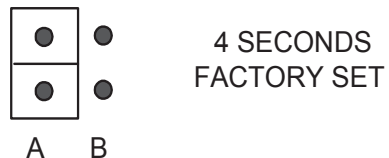

Diagram 19 4 Second Time Set Jumper



Perform an Inspection

- 1 XMS2 back plate is firmly mounted to the wall.
- 2 XMS2 cover is secured to back plate.
- 3 All wiring is securely connected to the board in the correct terminals.

Cleaning the XMS2

- 1 Verify viewing window is clear of all dust and debris.
- 2 Unit can be cleaned with a soft cloth.

Troubleshooting a XMS2

PROBLEM	SOLUTIONS
XMS2 does not power up.	<ul style="list-style-type: none">• Using a volt meter, confirm voltage is 12–24 VDC.
XMS2 LED flashes after release.	<ul style="list-style-type: none">• This is because power is being dropped to the XMS2 and Constant voltage should be supplied to + and - terminals.• Verify Voltage
XMS2 LED changes but does not drop voltage.	<ul style="list-style-type: none">• Verify the positive voltage is going to the IN+ terminal and out the DEV terminal. Reversing this can cause this effect.
XMS2 does not register when a person approaches the opening.	<ul style="list-style-type: none">• Verify the XMS2 barrel is aiming towards the point where it would pick up an approaching person and also verify the aiming screws are set up correctly and are open.

Warranty

For information on warranty coverage and replacement options, please visit [securitron.com/warranty](https://www.securitron.com/warranty)